



Data protection of virtual machines with HPE StoreEver Tape Libraries

Using Veeam Backup & Replication software



Contents

Executive summary.....	3
Technology overview.....	3
HPE StoreEver tape key features and benefits.....	3
HPE 3PAR StoreServ Storage key features and benefits.....	4
HPE Nimble Storage key features and benefits.....	5
Veeam Backup & Replication.....	5
Integrating HPE StoreEver Tape Libraries with Veeam Backup & Replication.....	5
Installation and configuration.....	5
Installation checklist.....	5
Discovering the tape library with Veeam Backup & Replication.....	6
Configuring Veeam Backup & Replication software.....	6
Restores from tape.....	11
Performance and tuning.....	12
File (data) compression ratio.....	12
Source disk and file systems.....	13
Tape drive.....	13
Conclusion.....	13



Executive summary

Many organizations are looking for ways to reduce power consumption, cooling requirements, and server footprint. Similarly, storage capacity is another major concern for businesses today. Moving to virtualized environments mitigates these concerns by providing an avenue to achieve data center consolidation. Likewise, moving virtual data from expensive disk-based storage to a less resource-intensive tape-based solution is a complementary strategy.

[Hewlett Packard Enterprise \(HPE\) StoreEver Tape Storage](#) provides dependable and scalable tape storage with enhanced security. Copying data to tape helps to reduce storage costs by moving data off expensive disk storage. Tapes can then be vaulted at an off-site repository for security and disaster recovery.

Protecting virtualized data presents its own unique challenges. Veeam® Backup & Replication is built specifically for backup and long-term retention of virtual environments. Starting with Veeam Backup & Replication v7, administrators can create an automated solution for moving virtual data from the disk storage tier¹ to inexpensive and dependable tape storage, greatly simplifying data management.

This document provides general guidelines and configuration information for configuring disk-based backup copies to tape using Veeam Backup & Replication with HPE StoreEver Tape Storage. Its target audience is IT system architects, solution architects, and system engineers.

Technology overview

A summary of the various products used in the data protection solution of this white paper provide a comprehensive understanding of the technologies involved.

HPE StoreEver tape key features and benefits

Along with new technologies in the market, traditional tape storage continues to offer customers a low-cost, lower risk, long-term retention solution for which there is still strong market demand.

HPE StoreEver tape products protect your data longer, for less

As the worldwide leader² in the entry-level tape segment, including stand-alone tape drives and autoloaders, HPE StoreEver Tape Storage is critical to comprehensive data protection and archiving. HPE StoreEver also addresses long-term retention needs. With one of the broadest and most advanced tape portfolios in the industry, HPE StoreEver supports Linear Tape-Open 8 (LTO-8). HPE StoreEver includes tape media, stand-alone tape drives, and tape libraries that accommodate more than 16.8 PB³ in a single system.

Veeam Backup & Recovery software supports HPE StoreEver 1/8 G2 Tape Autoloader and HPE StoreEver MSL tape libraries in an end-to-end solution.

HPE StoreEver:

- **Reduces total cost of ownership and management burden, enabling businesses to efficiently protect and retain rapidly growing data**

With support for LTO-8, the HPE StoreEver MSL6480 tape library and MSL3040 tape library lower cost per gigabyte for long-term storage. They offer up to 400 TB per 1U of rack space using LTO-8 drives. HPE MSL tape libraries provide the highest tape drive density per module of any midrange tape library with flexible options.

With HPE StoreEver, less power is required as frequently accessed data is stored or the media becomes full. For tiered storage and backup and recovery, HPE StoreEver can help improve price/performance by moving data that does not require fast access onto the lowest-cost tape tier. For cloud applications and disaster recovery, HPE StoreEver provides offline data protection and securely protects against natural disasters and data corruption.

- **Is reliable and allows customers to protect and retain data over the long term**

HPE StoreEver Tape Storage is ideal for archiving cold or active data with a media shelf life of up to 30 years in normal ambient conditions. HPE StoreEver Management Software includes HPE Command View for Tape Libraries (CVTL), HPE StoreEver TapeAssure Advanced, and HPE StoreEver Data Verification. This software suite provides an easy-to-use interface for efficiently managing, monitoring, and configuring an entire tape library environment.

HPE CVTL is management software that eases data protection with remote management, diagnostics, and configuration of all MSL tape libraries through a single console.

¹ For information about setting up the primary backup-to-disk environment, see [Veeam Software](#) or [Veeam Hyper-Availability for HPE](#) and choose the manual that is appropriate for the hypervisor.

² "Branded Tape Tracker," IDC, 2H 2017

³ Using 2.5:1 compression and a fully populated HPE StoreEver MSL6480 tape library



HPE StoreEver Data Verification software improves verification of a successful restore of critical business data from infrequently accessed LTO tape cartridges by periodically scanning tapes to validate the quality of data on each tape.

HPE StoreEver TapeAssure Advanced technology offers enhanced reliability, extreme durability, and proactive monitoring, so users can store essential but less frequently accessed data with confidence. HPE StoreEver TapeAssure Advanced makes managing, fine-tuning, and archiving faster and easier with comprehensive reports on status, performance, utilization, and health of all tape drives and media. An advanced analytics feature uses predictive analytics to determine the likelihood of failures, bottlenecks, and load balancing issues in the tape infrastructure. This data can be exported on demand or at scheduled times through HPE CVTL software.

- **Improves security and enables a vital last line of defense**

Tape's removable media is offline and less susceptible to threats such as viruses, hackers, and cyberattacks that can jeopardize data on disk. It is also a logically clean copy that cannot be accidentally overwritten by mirroring software.

LTO-8, LTO-7, and LTO-6 Ultrium tape drives include hardware-based data encryption to prevent unauthorized access to data at rest. LTO-8, LTO-7, and LTO-6 cartridges are available with write-once, read-many (WORM) capability to prevent accidental overwriting of data archived on the tape.

- **Delivers enormous scalability and answers data growth challenges**

HPE StoreEver MSL3040 and MSL6480 tape libraries deliver proven scalability and density for midrange tape automation. The unique modular design of the HPE StoreEver MSL3040 and MSL6480 includes a robotics feature to provide in-box scaling for greater performance, scalability, and reliability. Upgrades are fast and nondisruptive. The HPE StoreEver MSL3040 scales vertically from 40 to 280 cartridge slots to store up to 8.4 PB⁴ in a 21U rack space. The HPE StoreEver MSL6480 scales vertically from 80 to 560 cartridge slots to store up to 16.4 PB⁵ in a 42U rack space.

The HPE StoreEver MSL3040 scales from 1 to 21 LTO half-height (HH) tape drives. The HPE StoreEver MSL6480 scales from 1 to 42 LTO HH tape drives with transfer rates of 300 MB/s (native) per LTO-8 tape drive SAS or Fibre Channel.

HPE 3PAR StoreServ Storage key features and benefits

HPE 3PAR StoreServ is the industry's #1 midrange storage array⁶ and a leading all-flash array. From midrange to enterprise to all-flash arrays for unified file and block workloads, users can start with a few terabytes in a single system and scale to more than 80 PB in a four-system federation with a common operating system, feature set, and management.

Customize your storage quickly and easily to improve capacity utilization and deliver high service levels

HPE 3PAR StoreServ Storage is a family of storage systems that range from Tier 1 mission-critical solutions with the highest performance and scalability, supporting cloud and IT as service environments, to storage solutions with enterprise-class features at a midrange price, designed for the virtualized data center.

HPE 3PAR StoreServ is:

- **Efficient:** Reduce capacity requirements by 50%.⁷
- **Autonomic:** Simplify, automate, and expedite storage management by handling storage provisioning, tiering, and change management autonomically—intelligently, at a subsystem level, and without administrator intervention—reducing administration time by up to 90%.
- **Federated:** Meet the needs of today's data center with the ability to move data and workloads between arrays without impacting applications, users, or services. Simply and nondisruptively shift data between HPE 3PAR StoreServ systems without additional management layers or appliances.

⁴ Using 2.5:1 compression and a fully populated MSL 3040 tape library

⁵ Using 2.5:1 compression and a fully populated MSL 6480 tape library

⁶ IDC WW Disk Storage Systems Tracker CQ4 2016, March 2017

⁷ Requires the use of HPE 3PAR Thin Conversion software and HPE 3PAR Thin Provisioning software. For details, refer to the HPE 3PAR Get Thin Guarantee terms and conditions. More information is available at: <https://www.hpe.com/us/en/storage/3par.html#Guarantees> and <https://h20195.www2.hpe.com/V2/GetDocument.aspx?docname=A00020004ENW>



HPE Nimble Storage key features and benefits

HPE Nimble Storage All Flash Arrays combine a flash-efficient architecture with HPE InfoSight predictive analytics to achieve fast, reliable access to data and 99.9999% availability. Simple to deploy and use, the arrays are cloud-ready, providing data mobility to the cloud through HPE Cloud Volumes.

HPE Nimble Storage provides:

- **Predictive analytics:** Automatically predict and resolve 86% of problems before there are even any indications of an issue.⁸
- **Radical simplicity:** These arrays are extremely easy to integrate with many ecosystems and deeply integrate with VMware®, Microsoft®, Oracle, Veeam, and other applications.
- **Speed and reliability:** HPE Nimble Storage All Flash Arrays are scaled to fit. They scale up performance and capacity independently and nondisruptively. They also scale out to four arrays managed as one for increased flexibility.
- **Absolute resiliency:** HPE Nimble Storage All Flash Arrays have 99.9999% availability.

Veeam Backup & Replication

Veeam Backup & Replication is a data protection and disaster recovery solution for VMware vSphere and Microsoft Hyper-V virtual environments of any size and complexity. Combining all necessary functions in one intuitive interface, Veeam Backup & Replication serves to solve typical problems of virtualized infrastructure management and protects mission-critical virtual machines (VMs) from both hardware and software failures. The Veeam Backup & Replication solution presents several options for backing up or recovering VMs.

Primary backups

HPE and Veeam Backup & Replication software offer specific vSphere and Hyper-V protection solutions for virtual data center administrators. HPE and Veeam collaborated to solve inherent problems in the traditional agent-based backup model with a solution that is simple to license and implement at a low price point.

Veeam Backup & Replication software has been tested and proven to enhance VM backup when used with HPE Storage disk arrays and the HPE StoreOnce backup system family of disk-to-disk backup appliances. The HPE and Veeam data protection solution complements existing physical system backup tools. For more information, visit [Veeam Software](#) or [Veeam Hyper-Availability for HPE](#).

Long-term retention to tape

Veeam Backup & Replication users can copy/write backup files stored in backup repositories and regular files (such as Windows® and Linux® files) to tape for long-term or disaster recovery purposes. Veeam Backup & Replication enables file backup from any Windows or Linux server that has been added as a managed server to the Veeam backup console, including physical servers.

Integrating HPE StoreEver Tape Libraries with Veeam Backup & Replication

HPE has joined with Veeam to develop an end-to-end approach to making sure that all hardware, firmware, driver, and software components are properly fitted into certified and supported data protection and archiving solutions.

Installation and configuration

Before configuring and implementing a data protection and archiving solution, refer to the [HPE StoreEver Compatibility Matrix](#) for the latest HPE StoreEver interoperability and device compatibility details. The matrix contains tape device connectivity details including supported servers, operating systems, controllers, and infrastructure components, as well as backup and archive independent software vendor partner compatibility.

Installation checklist

If the answer to each of the following questions is “yes,” then all components on the SAN are logged in and configured properly:

- Are all the hardware components, including servers, host bus adapters (HBAs), Fibre Channel switches, CVTL, tape drives, and library robots, at the minimum supported firmware revisions specified in the current HPE StoreEver Compatibility Matrix?
- Is the minimum patch level supported for each operating system installed?
- Are the minimum supported drivers specified in the HPE StoreEver Compatibility Matrix installed (HBA, tape drives)?
- Is the HPE StoreEver tape library online, or are the partitions online?
- Is the Veeam backup server HBA correctly logged into the Fibre Channel switch?

⁸ Based on actual customer data collected by the HPE Nimble Storage support organization. See [Redefining the standard for system availability](#).



- If the Fibre Channel switches are cascaded or meshed, are all inter-switch link ports correctly logged in?
- Are all tape and robotic devices zoned, configured, and presented to each host from the Fibre Channel switch?
- Are the Veeam backup server HBA, tape, and robotic devices in the same switch zones?
- Does the Veeam backup server detect all the tape and robotic devices intended to be used?
- Are all HPE StoreEver storage devices seen by HPE CVTL?
- Has connectivity been verified using HPE Library and Tape Tools or operating system-specific tools (for example, the sg utility in Linux)?
- Is the primary disk-based Veeam backup environment correctly configured? For setup of the primary backup environment with Veeam Backup & Replication, refer to the [HPE 3PAR StoreServ and Veeam Backup & Replication](#) white paper and [Veeam and Nimble Storage Deployment Guide](#).

Discovering the tape library with Veeam Backup & Replication

After the devices are properly zoned and logged into the SAN, start Veeam Backup & Replication on the backup server. Veeam performs auto-discovery of the tape devices and tape media. After initial discovery, the auto-discovery process is performed every 30 seconds.

In cases where traditional backup software is also installed on the SAN to manage backups to the tape library, HPE recommends simplifying the management of complex environments with library partitioning.

Configuring Veeam Backup & Replication software

Veeam backups occur by moving VM data to a disk-based backup repository. Backups can then be copied to another disk-based storage device or to a tape-based storage device for data copy purposes. The next sections of this document describe the backup-to-tape portion of the backup stream.

For the purpose of this document, the following components were manually installed and configured in the order listed on a single, physical Windows host:

- **Veeam backup server:** The Veeam backup server is a Windows-based physical or virtual machine on which Veeam Backup & Replication is installed. It is the core component in the backup infrastructure that serves as the configuration and control center.
- **Veeam proxy server:** A backup proxy is an architecture component that sits between the data source and target. It is used to process jobs and deliver backup traffic. The role of a backup proxy can be assigned to a dedicated Windows server (physical or virtual) in the virtual environment. The primary roles of the backup proxy are to provide a more efficient route for backup traffic and enable efficient data transfer.
- **Veeam backup repository:** A backup repository is a location used by Veeam Backup & Replication jobs to store backup files, copies of VMs, and metadata for replicated VMs. Technically, a backup repository is a folder on the backup storage array. In this setup HPE recommends using HPE StoreOnce Catalyst.

Figure 1 illustrates the Veeam Backup & Replication architecture⁹ with data movement as follows:

1. The Veeam backup server sends a request to the Veeam proxy server, which in turn requests a VM snapshot from the hypervisor.
2. Veeam integration with HPE 3PAR StoreServ and HPE Nimble Storage allows the backup server to directly communicate with the production storage to request a crash- or application-consistent snapshot, which is performed by the array itself.
3. The Veeam backup server retrieves snapshots from production storage. After the backup server receives the snapshot, it deletes the original snapshot from the hypervisor.
4. VM data is copied from the production storage snapshot and stored to a Veeam backup file on the primary backup tier, according to the policy of the backup job.
5. The backup is sent to HPE StoreEver tape storage according to backup policies set by the administrator.

⁹ Figure 1 depicts data flow for a vSphere environment. Storage tiers remain the same in a Hyper-V environment, but the Veeam transport methods differ. See the [Veeam user guide for Hyper-V](#) for details on data flow.



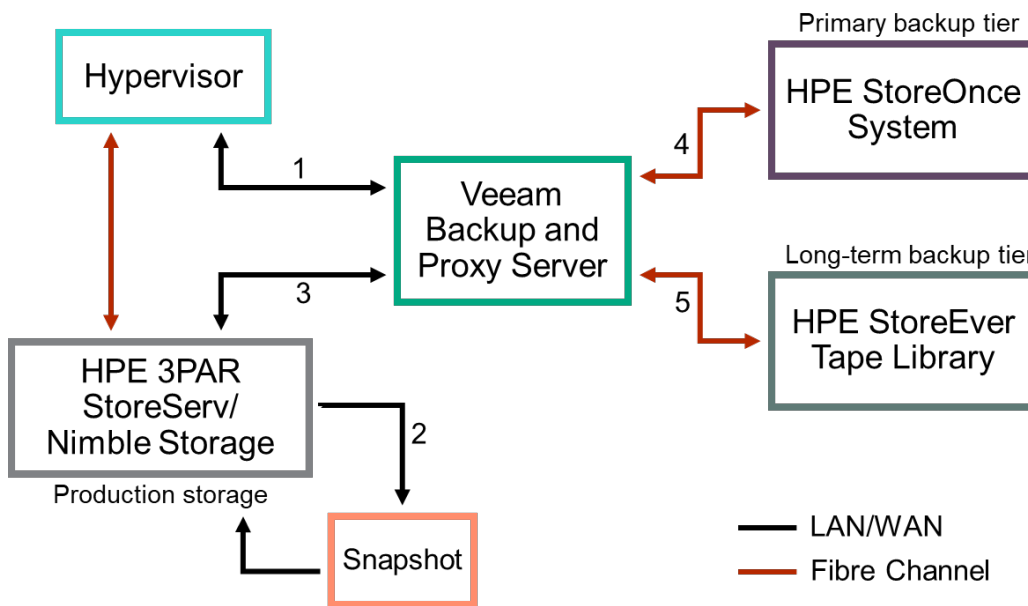

Figure 1. Veeam Backup & Replication data flow to HPE storage tiers

Initial setup

Before it is possible to configure a backup-to-tape job, the administrator must first create a primary backup to a disk-based repository. For initial setup and configuration of the software for Hyper-V and VMware environments, refer to the [Veeam user guide for Hyper-V](#) or the [Veeam user guide for VMware](#).

Tape library discovery is automatic when the Veeam Backup & Replication software is started if the backup server is attached to the HPE StoreEver tape library through SAS or Fibre Channel SAN. Refer to the [Installation checklist](#) section of this document for tape library connectivity recommendations.

Tape libraries and drives are displayed under the Backup Infrastructure pane in the Tape section, as illustrated on the left side of the screenshot shown in Figure 2. Several configuration wizards can be initiated from the right pane:

- The File to Tape wizard
- The Backup to Tape wizard
- The Restore File from Tape wizard
- The Restore Virtual Machine from Tape wizard



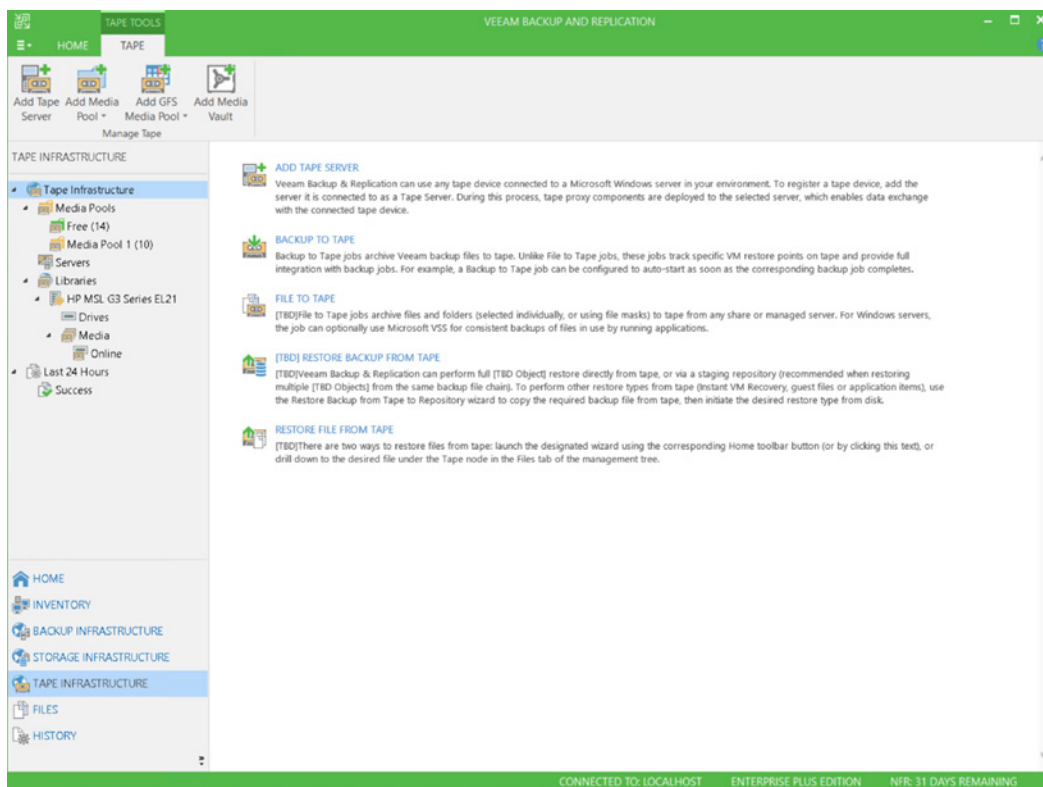

Figure 2. Veeam auto-discovers tape devices (left) and provides configuration wizards (right)

Note

The Add Tape Device heading is for information only and does not initiate a configuration wizard.

Media management

Before setting up individual tape jobs, it’s necessary to review media management and media pools. Media is initially discovered by Veeam and displayed in the Backup Infrastructure pane by expanding the **Tape** → **Media** options.

When the devices and tapes are first discovered, or when new tapes are loaded into the tape library, they are presented as Unrecognized. Use the tape inventory feature to identify unrecognized tapes. After inventory, tapes are displayed in a Free media pool.

Custom media pools

Moving tapes to a custom media pool can make it easier to track tapes and their usage. To create a custom media pool:

1. From the Backup Infrastructure view, go to the **Tape** section and navigate to **Media** → **Media Pools**. Alternatively, from the **Media** → **Online** view, you can right-click **Tapes** to move them to another pool.
2. Right-click **Media Pools** and select the **Add Media Pool** wizard to set up a custom pool and its attributes.
 - a. When adding media to the custom media pool, only tapes in the Free media pool can be moved to a custom pool using the wizard, as shown in Figure 3.
 - b. After adding tapes to the pool, name the Media Set and set a Retention Policy according to administrator requirements. This step completes setup.
 - c. When the custom media pool is set up, it is located in the Backup Infrastructure view under the Tape section. Navigate to **Media** → **Media Pools**, as shown in the left pane of Figure 3.



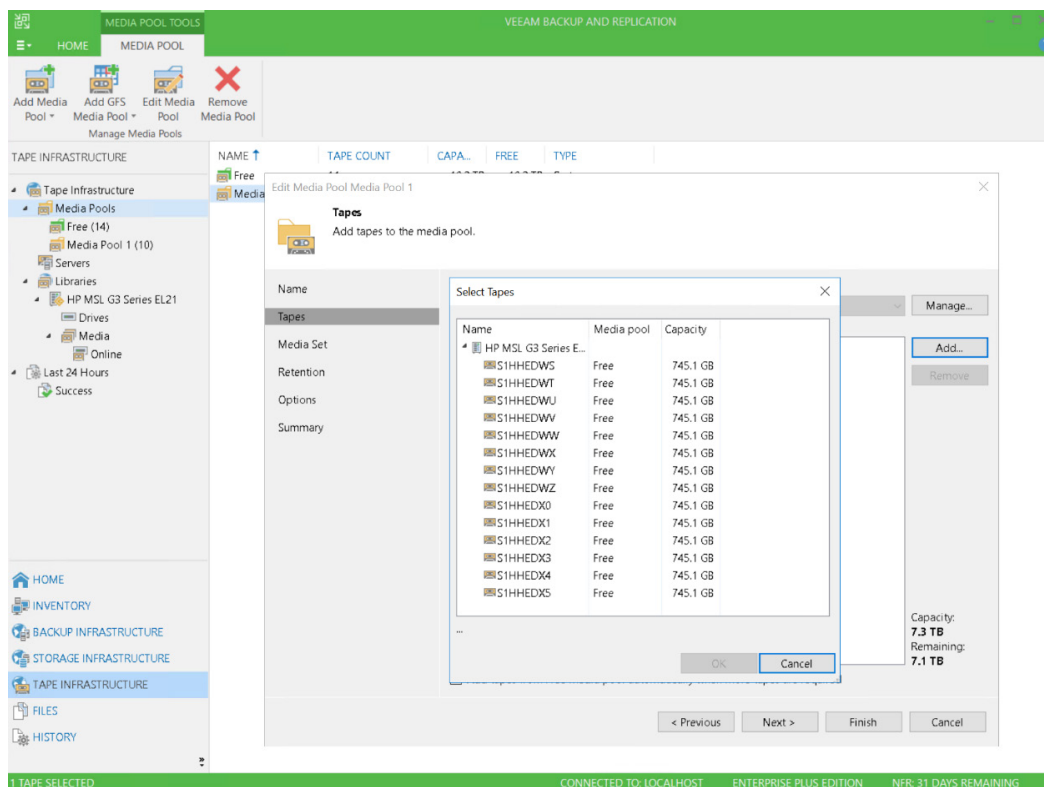

Figure 3. Select tapes from free media pool for custom pool

Back up to tape

Implementing data protection using Veeam Backup & Replication software involves moving existing primary backups to tape. Both Veeam backup jobs and entire Veeam backup repositories can be selected for copy to tape.

There are two options in Veeam for performing a copy to tape. Executing a new backup to tape allows the administrator to manually configure jobs for copying existing backups or repositories. Linking backups to tape allows the administrator to set a secondary target for archiving purposes during the initial backup configuration, thus automating the backup and archive workflow.

New Backup to Tape job

To initiate a backup-to-tape operation within Veeam Backup & Replication:

1. Run the Backup to Tape Job wizard; from the **Home** tab, click **Tape Job** and select **Backups**.
2. Specify the Name of the job and an optional description.
3. Choose backups or backup repositories to copy.
4. Select **Media Pool**. If you have already created custom media pools as described earlier in this document, they are displayed as an option at this stage of the wizard.
5. Specify **Options**.

Note

If using a tape library for any type of backup-to-tape job, check the **Eject media upon job completion** check box in the Options window. This box must be selected to ensure that Veeam sends a command to unload the tape from the tape drive and replace it in the media slot.



Linking backup jobs to backup-to-tape jobs

A tape copy can be linked to a primary backup in Veeam Backup & Replication by creating a secondary destination for the primary backup job setup, as shown in Figure 4.

Important

Using this option allows the administrator to automate both the primary backup-to-disk and the secondary copy-to-tape functions.

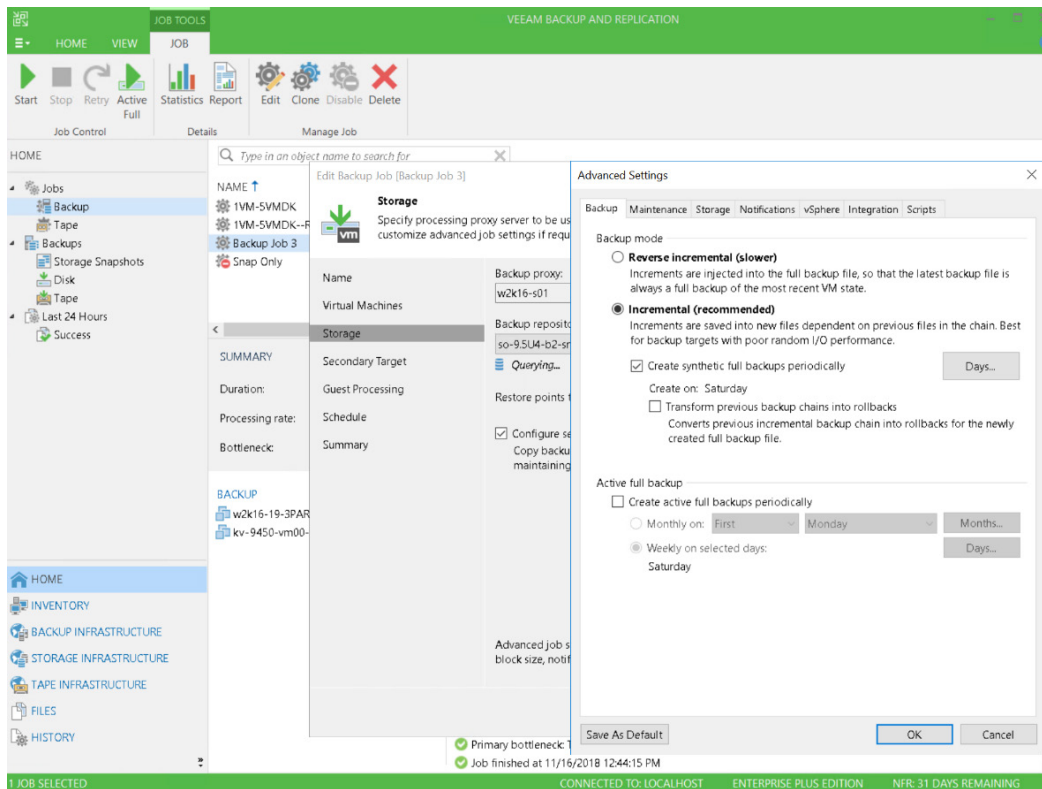

Figure 4. Linking primary disk backups to tape copy in the Veeam backup-to-tape policy

To link a tape copy to a primary backup:

1. From the Backup & Replication view, select a backup job from the right navigation pane, right-click the job, and select **Edit** to open the Edit Backup Job wizard. Alternatively, when setting up a new backup job, follow the steps described in the [New Backup to Tape job](#) procedure.
2. From the left navigation pane in the dialog box, click **Storage**. Select the check box labeled **Configure secondary destinations for this job**. Select the button on the lower right labeled **Advanced** to reduce the time required to move backups to tape. The Advanced Settings dialog box is displayed.
 - a. Ensure that the Incremental radio button is selected. Veeam recommends using incremental backup for disk-to-disk-to-tape operations to reduce the time required to move backups to tape.
 - b. Other settings are available as well. During the testing performed when developing this document, all settings were left as default.

New File to Tape job

File to Tape jobs allow the administrator to either copy specific files from the Veeam backup server to tape or send files from Windows and Linux servers that can be accessed by the Veeam backup server to tape. This process is like a traditional backup application. However, the movement of files occurs first across the LAN to the Veeam backup server, and then to SAS or SAN-attached tape.



Note

File to tape backup speeds are throttled by the movement of data over the LAN to the backup server. This might cause extended backup times.

To launch the File to Tape job wizard, perform one of the following actions:

- On the Home tab, click **Tape Job** and select **Files**.
- Open the Backup & Replication view, right-click **Jobs** and select **Tape Job** → **Files**.
- Open the Files view, browse to the necessary files, select the files, and click **Add to Tape Job** → **New job** from the ribbon menu.
- Open the Files view, browse to the required files, right-click the necessary files, and click **Add to Tape Job** → **New job**.

Restores from tape

This section outlines the following options for restoring VMs or files from tape with Veeam Backup & Replication:

- Restoring full backups or backup chains from a tape copy to disk
- Performing full VM recovery from a tape copy to the virtual infrastructure
- Restoring files and folders to their original location or any other folder

Restore backup from tape copy to disk

To restore a full backup from a tape copy to disk:

1. Run the Restore Backup from Tape to Repository wizard; from the Home tab, click **Restore** and select **Tape** → **Restore Backups**.
2. Choose VMs to restore from the prepopulated list of VMs copied to tape in the wizard.
3. Select a restore point. If you select a full backup point in the list, Veeam will restore only this full backup. If you select an increment, Veeam will restore a chain consisting of full backup and forward increments necessary to restore VMs to the required point in time. You can make different choices for each VM you choose to restore during a specific session.
4. Select a backup destination. Because you are restoring from a tape copy, Veeam will send the data to this intermediate storage destination. The wizard allows you to put the data on an existing backup repository, on a server that can be accessed by the Veeam backup server, or to a network share.
5. After the backup is restored from tape copy to a disk destination, it is displayed as an “imported backup” in the **Backup & Replication** → **Backups** → **Imported** view. From this point, you can select various data recovery methods described in the appropriate Veeam Backup & Replication user guide for the hypervisor.

Restore virtual machine from tape copy to the virtual infrastructure

The process to restore full VMs from tape copy has two stages. During the first stage, copied VMs are restored to an intermediate staging destination. The destination can be a backup repository or a folder. The second stage restores the VM into the virtual infrastructure. After the second stage is completed, the backup is deleted from the staging destination.

Stage 1

1. Run the Full VM Restore wizard by using one of two methods. You can open the Backup & Replication view and expand the **Backups** → **Tapes** option. Select the necessary VMs in backup. From the Backup on Tape ribbon, click **Restore entire VM**. Alternatively, open the Backup & Replication view and expand **Backups** → **Tapes**. Right-click the necessary VMs in backup and click **Restore entire VM**.
2. Follow the wizard. The same steps defined in the [Restore backup from tape copy to disk](#) section apply.

Stage 2

1. VMware:
 - a. Launch the Restore wizard by opening the Backup & Replication view and expanding **Backups** → **Tapes**. Right-click the necessary VMs in backup and click **Restore entire VM**.

Refer to the “Performing Entire VM Restore” section of the [Veeam Backup & Replication user guide for VMware](#) for instructions on how to use the wizard to complete the restore to the virtual infrastructure.



2. Hyper-V:

- a. Launch the Restore wizard by completing one of the following steps:
 - i. On the Home tab, click **Restore** and select **Hyper-V**. In the Restore from backup section, select **Entire VM (including registration)**.
 - ii. Alternatively, open the Backup & Replication view and select the **Backups** option. In the working area, expand the necessary backup job, select the VMs you want to restore, and click **Entire VM** on the ribbon.

Refer to the “Performing entire Full VM Restore” section of the [Veeam Backup & Replication user guide for Hyper-V](#) for instructions on how to use the wizard to complete the restore to the virtual infrastructure.

Restore files from tape

Restoring files from tape is like a traditional backup application in that you choose a file for restore and destination. That file is then restored to the destination directly from tape. As with the case of backing up files to tape, the file movement first occurs over the LAN to the Veeam backup server. Long restore times are possible because of LAN bottlenecks.

1. Run the Files from Tape wizard; from the Home tab, click **Restore**. Then select **Tape** → **Restore Files**.
2. Use the wizard to choose objects to restore, specify a destination, and define restore options.

Note

When using the restore files from tape option, restore speeds are throttled by the movement of data over the LAN to the backup server. This might cause extended restore times.

Performance and tuning

To analyze speed and performance, it is necessary to examine the entire backup and archive process as a system. Although many factors contribute to the overall performance of the system, there are five main factors that must be thoroughly understood to determine the maximum performance in any specific situation. These factors are:

- **Storage connection:** Data protection solutions with HPE StoreEver tape libraries use a Fibre Channel connection.
- **File (data) compression ratio:** The amount of compression directly impacts the rate at which a tape drive can read or write data.
- **Source disk and file systems:** Specifications include data source, local disk, RAID array storage, file system type, and volume type.
- **Tape drive:** In data protection solutions, these are the various types of tape drives in HPE StoreEver storage.

Note

To achieve beneficial results, first review the environment by installing the latest drivers and firmware, updating the network, and so on. Refer to the [Installation checklist](#) for more details.

File (data) compression ratio

HPE tests show that not all data can be compressed equally. The compression ratio affects the amount of data that can be stored on each tape cartridge, as well as the speed at which the tape drives can read or write the data. Table 1 shows typical compression ratios of various applications.

Table 1. Typical file compression ratios

Data type	Typical compression
CAD	3.8:1
Spreadsheet or Word processing	2.5:1
Typical file and print server	2.0:1
IBM Notes databases	1.6:1
Microsoft Exchange and SQL Server databases	1.4:1
Oracle and SAP® databases	1.2:1



Source disk and file systems

In the past, tape performance was typically identified as a bottleneck. However, tape performance has now surpassed many of the source systems available today. Items to consider when calculating desired throughput and performance metrics include:

- Source hardware (disk subsystems)
- Source file system status
- Server configuration

The following factors critically affect the speed of backup from disk to tape:

- **Data file size:** The larger the number of smaller files, the larger the overhead associated with backing them up. The worst-case scenario for backup is large numbers of small files because of system overhead of file accession.
- **Data compressibility:** Incompressible data backs up slower than higher compressible data. For example, JPEG files are not very compressible, but database files can be highly compressible. The accepted standard for quoting tape backup specifications is based on an arbitrary figure of 2:1 compressible data.
- **Disk array performance:** It is often overlooked that data cannot be put onto tape any faster than it can be read from disk. Backup is more sequential in nature than random (from a disk array access perspective). Disk array performance depends on the number of disks, RAID configuration, the number of Fibre Channel ports accessing the array, and queue depth available, among other factors.
- **Fragmentation:** The more fragmented the files are on disk, the more random the disk access method. This means the backup will take longer. If the system has a defragmentation utility, it is advisable to run it before full backups or on a regular schedule to verify that files are contiguously arranged on the disk.

Tape drive

The tape drive is another factor in determining backup and restore performance. HPE StoreEver tape drives have varying levels of performance. Factors such as file size (larger is better), directory depth, and data compressibility all affect system performance. Data interleaving during backup also affects restore performance. Table 2 shows performance information for various HPE StoreEver tape drives.

Table 2. Tape drive throughput speed (native)

Tape drive	Native throughput MB/s
Ultrium 30750 (LTO-8 HH)	300
Ultrium 15000 (LTO-7 HH)	300
Ultrium 6250 (LTO-6 HH)	160
Ultrium 3000 (LTO-5 HH)	140
Ultrium 1760 (LTO-4 HH)	80

Conclusion

Enterprise server customers demand an efficient, reliable virtual data backup and archiving solution while keeping costs under control. HPE Storage provides a variety of reliable data storage solutions that address such requirements.

HPE StoreEver storage with Veeam Backup & Replication can provide a complete disk-to-disk-to-tape implementation. HPE StoreEver tape systems offer significant cost, energy, and footprint advantages, while addressing data growth by adding drives and capacity on demand as needed. Overall, HPE StoreEver tape systems integrate easily with Veeam Backup & Replication and are a critical component for comprehensive data protection and archiving of mission-critical applications.



Resources and additional links

HPE Storage products

hpe.com/storage

HPE StoreEver Compatibility Matrix

h20272.www2.hpe.com/SPOCK/Pages/spock2Html.aspx?htmlFile=hw_storeever.html

Veeam and HPE

veeam.com/hpe-availability-solution.html

Veeam Backup & Replication

veeam.com/documentation-guides-datasheets.html

VMware vSphere

vmware.com/products/vsphere

Microsoft Hyper-V

<https://docs.microsoft.com/en-us/windows-server/virtualization/hyper-v/Hyper-V-on-Windows-Server>

Veeam Backup & Replication 9.5

veeam.com/vm-backup-recovery-replication-software.html

Learn more at

hpe.com/storage/storeever

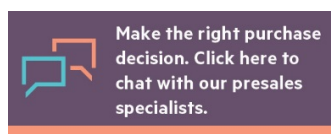

 **Share now**

 **Get updates**

© Copyright 2018 Hewlett Packard Enterprise Development LP. The information contained herein is subject to change without notice. The only warranties for Hewlett Packard Enterprise products and services are set forth in the express warranty statements accompanying such products and services. Nothing herein should be construed as constituting an additional warranty. Hewlett Packard Enterprise shall not be liable for technical or editorial errors or omissions contained herein.

Linux is the registered trademark of Linus Torvalds in the U.S. and other countries. Microsoft and Windows are registered trademarks of Microsoft Corporation in the United States and/or other countries. Oracle is a registered trademark of Oracle and/or its affiliates. SAP is the trademark or registered trademark of SAP SE in Germany and in several other countries. VMware is a registered trademark or trademark of VMware, Inc. and its subsidiaries in the United States and other jurisdictions. All other third-party marks are property of their respective owners.